

THIS DRAWING IS UNPUBLISHED. RELEASED FOR PUBLICATION .18
 COPYRIGHT 19 BY AMP INCORPORATED. ALL INTERNATIONAL RIGHTS RESERVED.

LOC	DIST	ZONE	LTR	REVISIONS	DATE	APPD
G	14		A	REVISED PER 0720-0230-93	2/25/94	JAP

METRIC
 DIMENSIONS LISTED IN mm [INCHES]

AMP WIRE RANGE	E13288 Listed
22-16 AWG STRANDED	22-16 AWG STRANDED
LR7189 Certified	MILITARY P/N AND CLASS
NOT CERTIFIED	NOT APPLICABLE

STAMP AMP 22-18* APPROX AS SHOWN
 22-16 TERMINALS ARE STAMPED 22-18 IN
 ACCORDANCE WITH MILITARY SPECIFICATION
 MIL-T-7928, COMMERCIAL WIRE RANGE IS 22-16

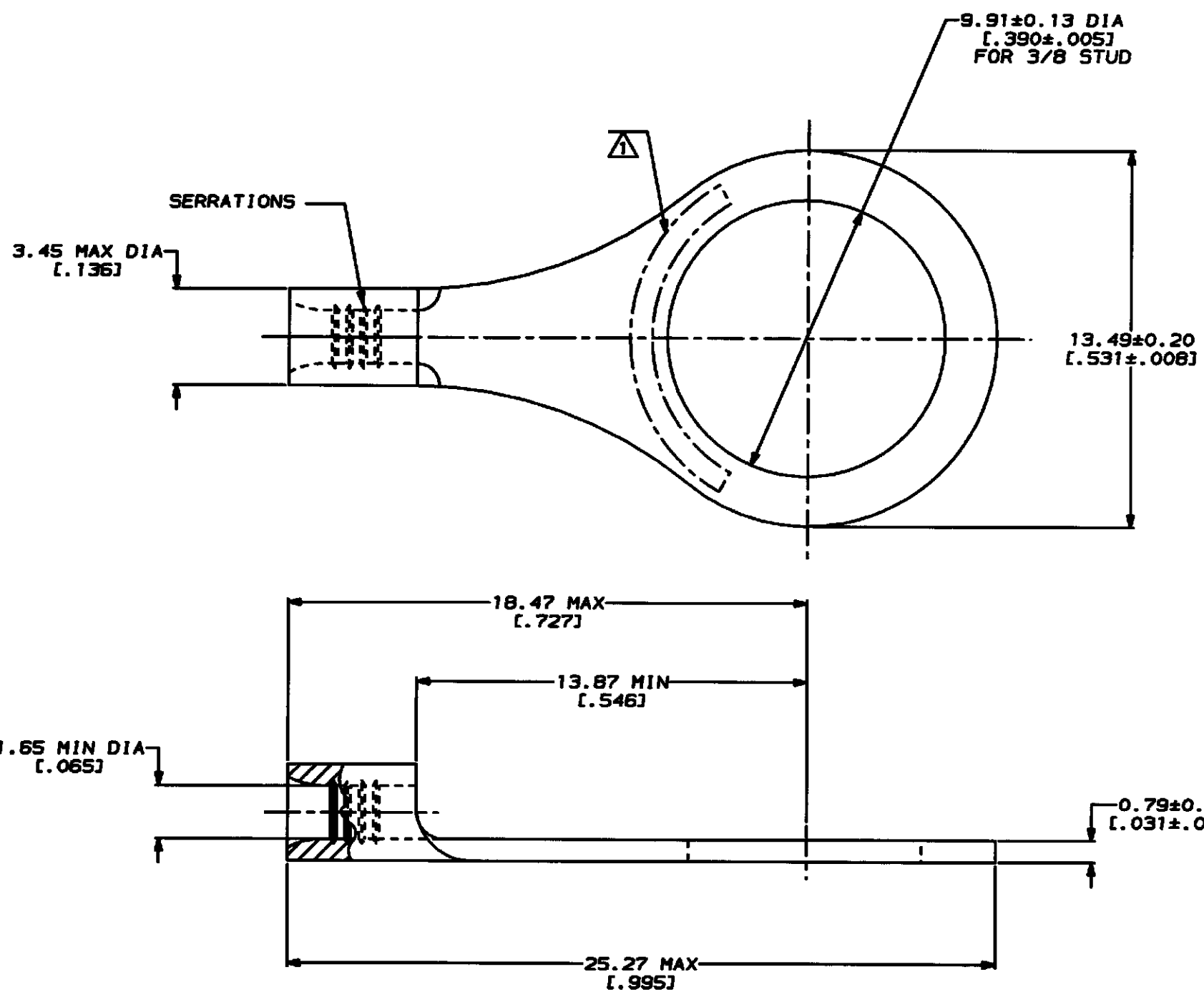

31498

AMP INCORPORATED CUSTOMER SERVICE SYSTEMS		MAX RECOMMENDED OPERATING TEMPERATURE: 170°C MAX	DO NOT SCALE PRINT. UNLESS SPECIFIED DIMENSIONS IN mm [INCHES] TOLERANCES ON: 2 PLC DEC ± - 3 PLC DEC ± - ANGLES ± -	DR 2-4-93 TA BRINKMAN CHK 2-4-93 DA PATTERSON APPD 2-4-93 DE MILLER APPD 2-4-93 JL HECKLEY PRODUCT SPEC APPLICATION SPEC	31498 PART NO		
FOR ADDITIONAL PRODUCT INFORMATION OR COPIES OF DRAWINGS AND TECHNICAL DOCUMENTS	PRODUCT INFORMATION CENTER 1-800-522-6752	VOLTAGE RATING: NOT APPLICABLE	COPPER PER ASTM B-152 ANNEALED	AMP AMP Incorporated Harrisburg, PA 17105-3608		NAME TERMINAL, RING TONGUE, BUDGET	
FOR APPLICATION TOOLING INFORMATION	TOOLING ASSISTANCE CENTER 1-800-722-1111	WIRE CROSS SECTIONAL AREA RANGE: 0.26-1.65mm ² [509-3,260] CIR MILS STRANDED	FINISH TIN PLATE 0.00254 [.000100] MIN THK PER MIL-T-10727	SIZE C	CAGE CODE 00779		DRAWING NO C-31498
FOR ORDER ENTRY	1-800-526-5142	THIS DRAWING IS A CONTROLLED DOCUMENT AND THE SPECIFICATIONS FOR THE LATEST REVISION SHOULD BE OBSERVED FOR THE LATEST REVISION.	WEIGHT	SCALE 8:1	SHEET 1 OF 1		
AMP 1471-6 REV 3-92							

CUSTOMER DRAWING